

DESCRIPTION

A 3 in 1 prefabricated panel that includes a FRANSYL IZOLON® insulation board, a 13 mm (1/2") cover board, and an underlayment membrane. The underlayment membrane is made of non-woven reinforced polyester with a thermofusible surface. The panel also features a 76 mm (3") double-sided self-adhesive overlapping strip and a 38 mm (1 1/2") overlapping protection strip.

COMPLEMENTARY PRODUCTS

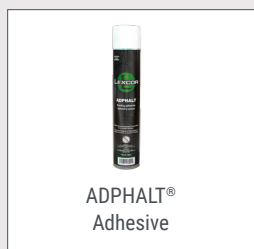

PHYSICAL PROPERTIES

THR (type 2) Expanded Polystyrene

Thermal Resistance (ASTM C518 C177) Thickness of 25 mm (1")	RSI-0.7 R-4
Vapour Permeability (ASTM E96) Thickness of 25 mm (1")	3.5 perm 200 ng/Pa·s·m ²
Compressive Strength (ASTM D1621) Thickness of 38 mm (1 1/2")	120 kPa 17.46 lbs/in ²
Flexural Strength (ASTM C518 C203) Thickness of 38 mm (1 1/2")	240 kPa 34.97 lbs/in ²
Water Absorption (ASTM D2842) Thickness of 38 mm (1 1/2")	4%
Density (ASTM D1621)	20.01 kg/m³ 1.25 lbs/ft ³
Limiting Oxygen Index (ULC S-701) % minimum	24%
Dimension Stability (ASTM D2126) % max. of linear change	1.5%

CERTIFICATIONS



- Meets CAN/ULC S-107 Standard
- C7 and C12 under CAN/ULC S-126M Standard
- UL Standard 790 (ASTM E 108)
- UL Class A with most roofing membrane systems (See UL Directory of Roofing Systems and Materials)
- UL Class C fully adhered (ref. TGFUC.R16778) POLYBASE R+ with cap sheet
- CSA 123.21

INSTALLATION

1. If adhered with adhesive, refer to the technical data sheet of the adhesive used for application recommendations.
2. Place the panels in close contact, without leaving a gap, and align the joints for the placement of the transverse sealing tape.
3. Remove the protective film under the side overlap strips and adhere them. Seal them by heating them with a torch on the surface. Weld a 152 mm (6") heat weldable elastomeric overlapping strip to the transverse joint.
4. In the place of drains, vents, and other accessories, an additional piece of flashing membrane measuring 1 m x 1 m (39" x 39") should be torched on to the base sheet membrane.
5. If mechanically attached, use the appropriate LEXCOR LEXGRIP screws and plates. Follow FM recommendations for the number of mechanical fasteners to be used per panel.
6. The modified bitumen cap sheet membrane needs to be fully unrolled and left for 15 minutes before it is adhered, regardless of the temperature. Furthermore, it's recommended to relax the membrane using a torch, applying its heat in a zigzag motion.

Important note: It is possible that blisters are formed in the membrane when the temperature increases; this has no impact on the performance and adhesion of the membrane on the panel. Blisters under the membrane will fade upon cooling of the panel.

Continued on back

POLYBASE R+ 180

TYPE THR

3 IN 1 PREFABRICATED PANEL

PHYSICAL PROPERTIES

Cover Board

Min. requirement as per ASTM C1289 or CAN/ULC S704

Nominal Thickness **12.5 mm**
0.5"

Thermal Resistance **RSI-0.44**
(ASTM C518) R-2.5

Water Vapour Transmission **< 1.5 perm**
(ASTM E96) < 85.8 ng/Pa·s·m²

Water Absorption
(ASTM C209) **< 4.0%**
(ASTM C1763) **< 4.0%**
(ASTM D2842) **< 3.5%**

Compressive Strength **90¹**
(ASTM D1621)

Dimensional Stability **< 0.5%**
(ASTM D2126)

Tensile Strength **> 95 kPa**
(ASTM D1623) > 2000 psf

Smoke Development **< 450²**
(ASTM E84/UL723)

Flame Spread **< 75²**
(ASTM E84/UL723)

Service Temperature **-73°C to 121°C**
(-100°F to 250°F)

¹551 kPa (80 psi) minimum, up to 758 kPa (110 psi)

²Numerical ratings are not intended to reflect performance under actual fire conditions. Flame spread index of ≤75 and smoke development ≤450 meet code requirements for foam plastic roof insulation. Physical properties listed above are presented as typical average values as determined by referenced ASTM test methods and are subject to normal manufacturing variation.

BASE SHEET MEMBRANE

Base sheet membrane consists of a heavy duty non-woven polyester enhanced with glass fiber strands and selected SBS modified bitumen. The surface is covered with a micro thermofusible poly film for heat welding. The base sheet membrane meets the requirements of CSA A123.23 Type B, Grade 3.

SIZES

Width x Length* **914 mm x 2.438 mm**
36" x 96"

Thickness - Shiplapped Edge **51 mm to 203 mm**
2" to 8"

Shiplap **16 mm**
5/8"

Number of Panels per Skid Varies according to thickness

*Other sizes available on special order. Sizes may vary ± 2%

INSULATED VALUES / THICKNESSES

R-10.5	76.2 mm (2.5")
R-12.5	88.9 mm (3")
R-14.5	95.3 mm (3.5")
R-16.5	101.6 mm (4")
R-18.5	114.3 mm (4.5")
R-20.5	127.0 mm (5")

ADVANTAGES

Increased Site Productivity

The simplicity and efficiency of panel installation greatly increases the speed of execution on the job site.

Monolithic Panel

Up to 203.2 mm (8") thick to meet the required R-Value in one application.

Environmentally Friendly

Without hot bitumen, odourless, VOC free.



PRODUCT WARRANTY

Thermal Value is 100% Guaranteed

The thermal resistance of the product is 100% guaranteed free of charge for a period of at least 40 years.



POLYBASE R+ 180

TYPE THR

3 IN 1 PREFABRICATED PANEL

INSTALLATION DIAGRAM FOR MECHANICAL FASTENING

DETAIL #1

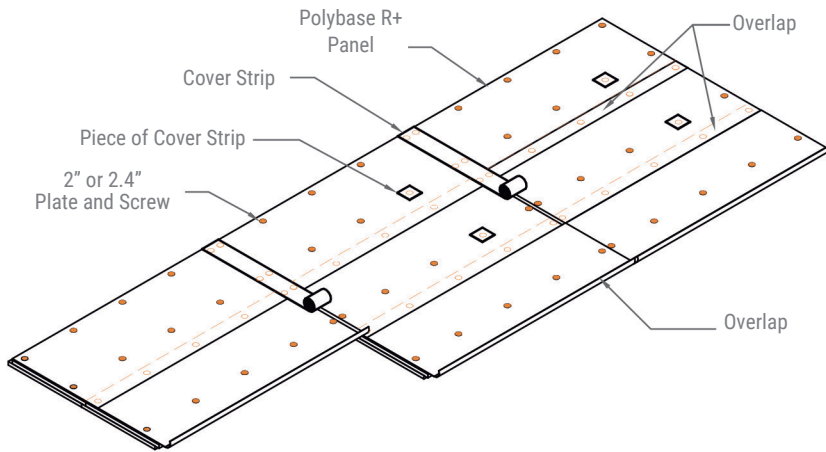

DETAIL #3

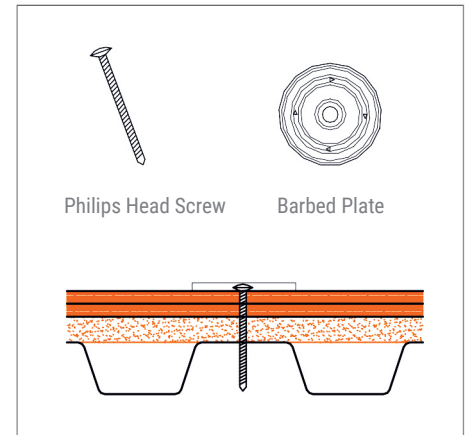

Cover Strip is required even if the cap sheet is installed in the same day.

DETAIL #2

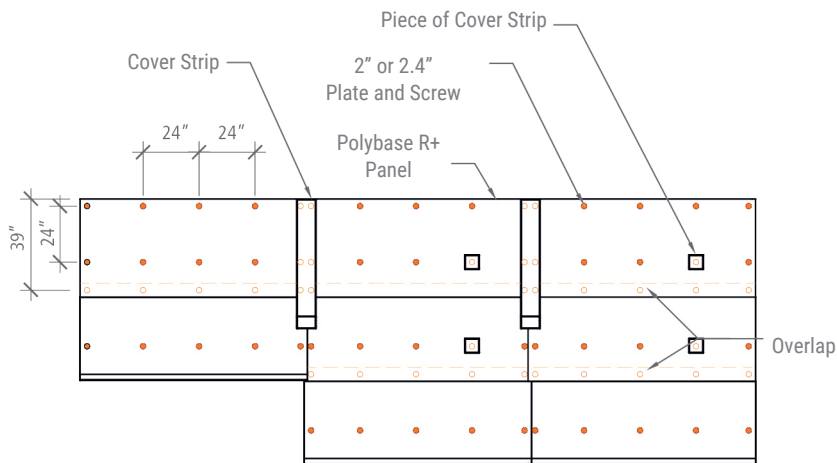

Mechanical fasteners must penetrate at least 19 mm (3/4") in steel deck, 25.4 mm (1") in wood deck and 12.7 mm (1/2") in plywood deck. For steel deck, the fastener must penetrate the deck on the higher part of the flute. Use 50 mm (2") or 60 mm (2.4") barbed steel plates depending on the application. Fasteners should be placed at a minimum 25.4 mm (1") of the edge of the panel to provide adequate support.

